



## Hygienic Sight Glasses

The In-line and Full-view hygienic sight glasses offered by Staitech are suitable for a wide range of applications in high purity tubing systems typically found in the Pharmaceutical and Biotechnology industries.

Both ranges are full bore designs whereby the internal diameter of the end connections and glass match those of tubing systems. This feature ensures that the sight glasses are free-draining and avoids the possibility of fluid retention.

The units combine 316L stainless steel end connections with a toughened borosilicate viewing glass making them suitable for both clean-in-place (CIP) and sterilisation-in-place (SIP) operations. Standard units are available in 1/2" to 2" sizes with Tri-Clamp® compatible connections. Alternative sizes and connections can also be supplied.

The In-line sight glass model is a compact double window design which offers a wide viewing aperture. Where there is a risk of accidental damage to the viewing glass a Polycarbonate knock shield can be supplied.

For applications where a larger aperture is required the Full-view range is available. Offering unobstructed viewing, this range are fitted with a knock shield as standard.

### Features offered by the hygienic sight glass range include:

- Full bore flow path - eliminates possibility of fluid retention.
- Easy to install - compact designs with large viewing area.
- Polycarbonate knock shields - protects glass against accidental damage.
- Can be cleared in-situ - suitable for CIP and SIP operations.

# Hygienic Sight Glasses

Listed are key design features offered by the Hygienic Sight Glass ranges.

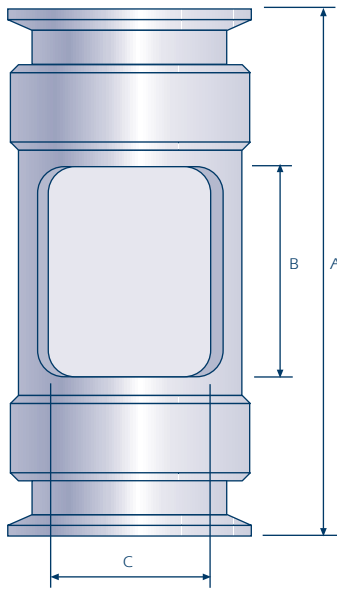

IN-LINE MODEL

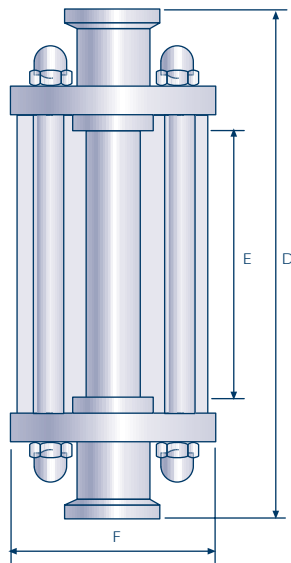

FULL-VIEW MODEL

## Sizes & connections

- 1/2", 3/4", 1", 1-1/2" & 2" Tri-Clamp® compatible

## Operating conditions

- 6 barg at 165°C
- Maximum allowable instantaneous temperature - 120°C

## Materials of construction

- End connections - 316L stainless steel
- Glass - borosilicate
- Viewing tube (In-line model) - stainless steel
- Tie rods (Full-view model) - stainless steel
- Seals - PTFE composite (FDA compliant)
- Knock shield - Polycarbonate

## Surface finish

- Internal - maximum 0.5 microns Ra
- External - maximum 0.8 microns Ra

## Available options

- Electropolishing
- PTFE liners
- Larger sizes
- Higher pressure units
- Alternative lengths/connection types

## Certification

- Material certification covering wetted parts - standard

## Dimensions (mm)

Size	A	B	C*	D	E	F
1/2"	110	45	120°	145	70	54
3/4"	110	45	120°	145	70	54
1"	125	48	110°	160	80	84
1-1/2"	125	48	110°	160	80	84
2"	140	55	110°	175	95	105

\* In-line sight glasses have two windows at 180° separation.

## Packaging

- All sight glasses are assembled in a clean environment and sealed in a polythene bag prior to packing

Further information covering all models is available upon request.

## Distributor

# Stai·tech

Staitech Ltd ▪ PO Box 152 ▪ Stroud  
Glos ▪ GL6 8YT ▪ UK

Tel: +44 (0) 1453 882736 ▪ Fax: +44 (0) 1453 882744

Email: enq@staitech.com Web: www.staitech.com